

2106 ELEMENT 3/2-Wege



Pneumatically operated 3/2 way seat valve ELEMENT for decentral- ized automation

- For mixing or distributing mediums
- Decentralized automation with control head
- Flow optimized body in stainless steel
- Long service life and maintenance-free operation
- Control Head is connected without external tubing

Type 2106 can be combined with...



Type 8691

Control Head



Type 8695

Control Head



Type 8690

Pneumatic
Control Unit



Type 8697

Pneumatic
Control Unit



The Bürkert 3/2 way seat valve, Type 2106, consists of a pneumatically operated ELEMENT actuator and a 3 way stainless steel valve body. Interchanging of pressure and service ports enables different fluidic circuit functions, such as the mixing or distributing of mediums. The flow-optimized valve body of Type 2106 allows excellent flow rates. The tried and tested self-adjusting gland secures a high level of tightness and thus ensures reliable operation over years. The design of the 3/2 way valve, Type 2106, offers all the advantages of a modern, decentralized automation: The directly connected control head and actuator provide a compact and smooth design, integrated pneumatic lines, protection class IP65/67, NEMA Type 4X, and a high chemical resistance. An optionally integrated fieldbus interface or even explosion proof device versions are further advantages of the 3 way shut-off valve. For the user, the compact Type 2106 is thus often an economical alternative to two single valves.

Technical data	
Orifice	DN15 to DN50
Port connections	G thread acc. to EN ISO 228-1 NPT acc. to ANSI B 1.20.1 (RC thread on request)
Body material	Cast stainless steel 316L
Nominal pressure	PN16 (Body)
Actuator material	PPS / Stainless steel 1.4561 (316Ti)
Sealing material	PTFE
Medium	Water, alcohol, oils, fuels, hydraulic fluids, salt solution, alkali solutions, organic solvents, steam
Viscosity	max. 600 mm ² /s
Spindle packing	PTFE V-rings with spring compensation
Medium temperature	- 10 to + 185 °C
Ambient temperature	- 10 to + 60 °C (integrated control head) - 10 to + 100 °C (push-in air ports)
Control medium	Neutral gases, air
Max. pilot pressure	max. 10 bar; actuator size 130 mm, 7 bar
Pilot air ports	Push-in connector for external Ø 6 mm or 1/4" tube, thread G 1/8 (on request)
Installation	As required, preferably with actuator in upright position
Approval and Conformity	EGV 1935/2004 (standard) FDA (optional)

Content

Valve specifications		System spec. On/Off ELEMENT		Request for quotation	
Type 2106		Type 8801-GE		Type 8801-GE	
Technical data & ordering info.	p. 5	Technical data & ordering info.	p. 6		p. 7

Ordering information for decentralized automation of On/Off ELEMENT valve system Type 8801-GE

A decentralized, automated **On/Off ELEMENT valve system Type 8801-GE** consists of a **seat valve Type 2100** and a valve control head **Type 8691/8695** or a pneumatic control unit **Type 8690/8697** (see separate datasheets).

For the configuration of further valve systems please use the "Request for quotation" on page 7 - 8

You order two components and receive a complete assembled and certified valve.

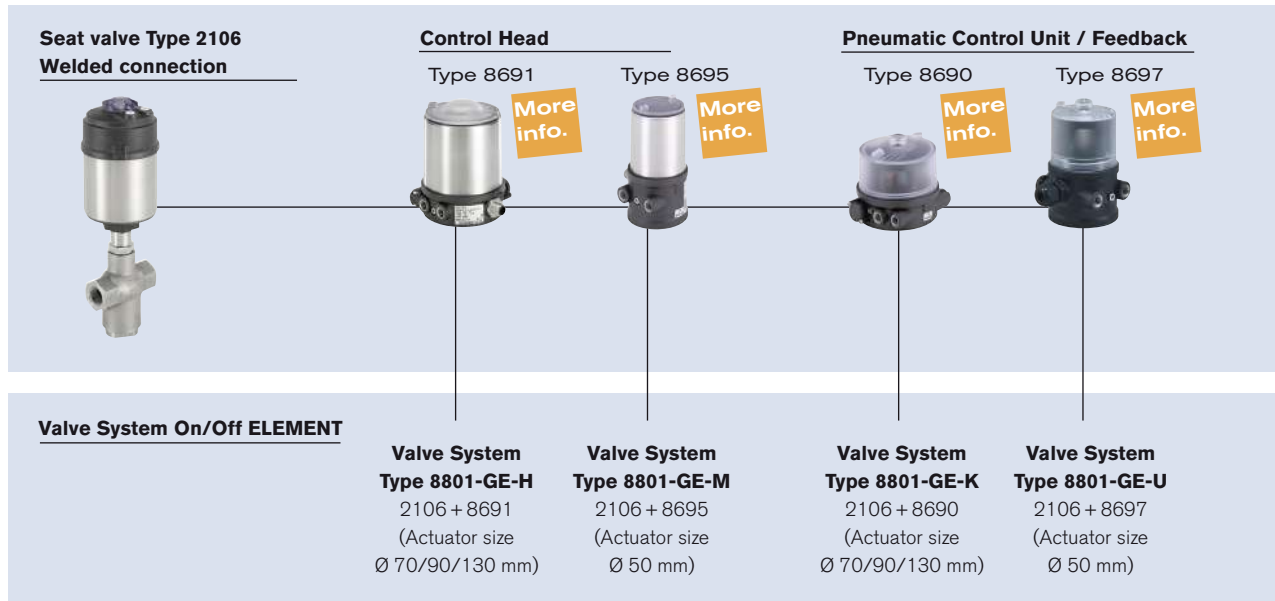

Control Head

Type 8691	Type 8695
Actuator size Ø 70/90/130 mm	Actuator size Ø 50 mm

The Control Head Type 8691/ 8695 is optimised for integrated mounting on the 21XX process valve series. The registration of the valve end position is done through a contactless analog position sensor, which automatically recognises and saves the valve end position through the Teach function when starting up. The integrated pilot valve controls single or double-acting actuators. The status of the valve is shown through high power coloured LEDs.

Features

- High power coloured Status-LEDs
- Contactless inductive position sensor
- Pilot valve with manual override
- Teach function for automatic registration of valve positions
- Hygienic stainless steel design
- Easy to clean chemically resistant housing featuring IP65 / IP67, 4X Rating
- AS-Interface or DeviceNet Fieldbus communication

Benefits

- Easy and safe Start-up through Teach function
- Easy process monitoring and error detection through clearly visible high-power coloured LEDs
- High plant availability due to prolonged actuator life boosted by spring chamber ventilation
- Minimised space requirement in the plant piping for more flexibility in plant design

Pneumatic Control Unit / Feedback

Type 8690	Type 8697
Actuator size Ø 70/90/130 mm	Actuator size Ø 50 mm

The pneumatic control unit Type 8697/8690 is optimised for integrated mounting on the 21XX process valve series. Mechanical or inductive limit switches register the position of the valve. The integrated pilot valve controls single or double-acting (8690) actuators.

Features

- Visual position indicator
- Mechanical or inductive limit switches for end position registering
- Pilot valve with manual override
- Compact design
- Easy to clean chemically resistant housing featuring IP65 / IP67, 4X Rating
- Optional intrinsically safe version acc. to ATEX

Benefits

- Easy and safe Start-up through Teach function (Type 8697)
- High level of signal reliability thanks to self adjusting limit switches
- Minimised space requirement in the plant piping for more flexibility in plant design

Click on the orange box "More info"... you will come to our website for the resp. product where you can download the data sheet.

Materials

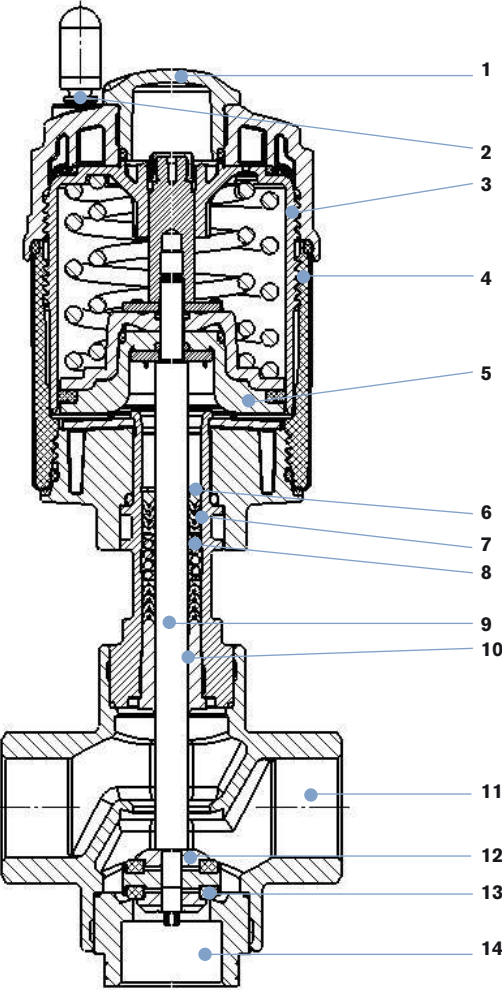

1 Transparent cap	Polysulfone PSU
2 Pilot air ports	Hose connectors PP (standard) <i>On request:</i> <i>G 1/8" thread, stainless steel 1.4305</i>
3 Actuator	PPS
4 Case	Stainless steel 1.4561 (316Ti)
5 Piston seal	FKM
6 Spring	Stainless steel 1.4310
7 Tube	Stainless steel 1.4401 (316)/1.4404 (316L)
8 Spindle seal	PTFE
9 Spindle	Stainless steel 1.4401 (316)/1.4404 (316L)
10 Spindle guide	PEEK
11 Valve body	Stainless steel 1.4404 (316L)
12 Body closer	Stainless steel 1.4404 (316L)
13 Seal	PTFE
14 Seat nipple	Stainless steel 1.4404 (316L)

The lubricants for stem packing and driving are classified according to NSF H1

Pilot pressure chart

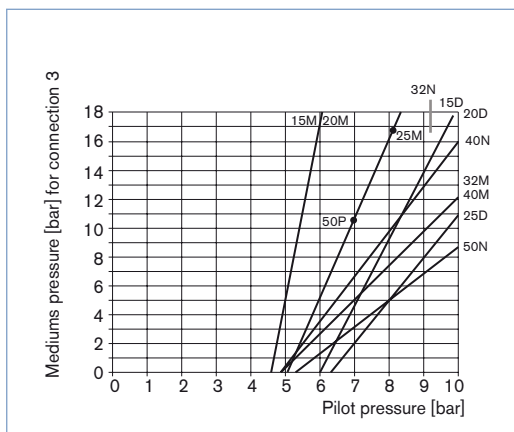

Key to actuator size D, M, N, P, see first column of table on page 4

Connections for fluidic circuit functions C, D, E and F

Actuator with control function A

When de-energised port connection 1 is closed with spring

Fluidic circuit function	Connection - port		
	1	2	3
C	P	A	R
D	R	A	P
E	P1	A	P2
F	A	P	B

A, B service ports
P, P1, P2 pressure ports
R exhaust port

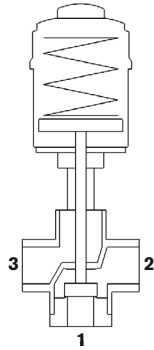

C

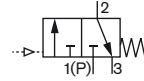

When de-energised, pressure port 1 closed, service port 2 exhausted

D

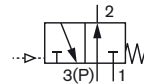

When de-energised, pressure port 3 connected to service port 2, exhaust port 1 closed

E

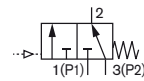

Mixer valve

When de-energised, pressure port 3 connected to service port 2, pressure port 1 closed

F

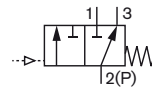

Distributor valve

When de-energised, pressure port 2 connected to service port 3 service port 1 closed

Dimensions [mm]

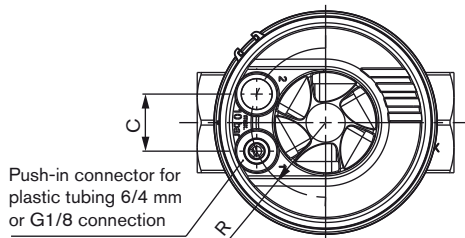
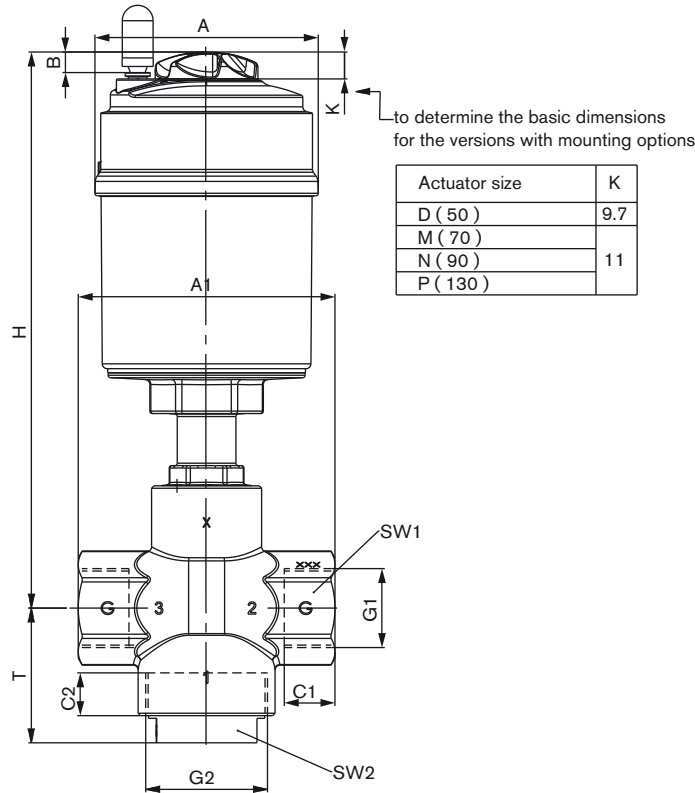

DN	Actuator size Ø	Ø A	B	C	R	H	All threaded bodies					G			NPT			RC		
							A1	T	G 2	SW1	SW2	G 1	C1/C2	LTA	G 1	C1/C2	LTA	G 1	C1/C2	LTA
15	D(50)	64.5	6.0	19.8	19.8	202.4	85	58.3	M40 × 1.5	32	30	G ½	14	GM84	NPT ½	13.7	NM84	RC ½	13.2	RC84
	M(70)	91	8.5	23.3	30.5	202.4	85	58.3	M40 × 1.5	32	30	G ½	14	GM84	NPT ½	13.7	NM84	RC ½	13.2	RC84
20	D(50)	64.5	6.0	19.8	19.8	202.4	85	58.3	M40 × 1.5	32	30	G ¾	16	GM85	NPT ¾	14.0	NM85	RC ¾	14.5	RC85
	M(70)	91	8.5	23.3	30.5	202.4	85	58.3	M40 × 1.5	32	30	G ¾	16	GM85	NPT ¾	14.0	NM85	RC ¾	14.5	RC85
25	D(50)	64.5	6.0	19.8	19.8	227.4	105	54.9	M50 × 2	41	41	G 1	18	GM86	NPT 1	16.8	NM86	RC 1	16.8	RC86
	M(70)	90	8.5	23.3	30.5	227.4	105	54.9	M50 × 2	41	41	G 1	18	GM86	NPT 1	16.8	NM86	RC 1	16.8	RC86
32	M(70)	91	8.5	23.3	30.5	234.7	130	67.8	M70 × 2	55	55	G 1 ¼	20	GM87	NPT 1 ¼	17.3	NM87	RC 1 ¼	19.1	RC87
	N(90)	120				294.4	130	78.1	M70 × 2	55	55	G 1 ¼	20	GM87	NPT 1 ¼	17.3	NM87	RC 1 ¼	19.1	RC87
	P(130)	159				346.7	130	68.0	M70 × 2	55	55	G 1 ¼	20	GM87	NPT 1 ¼	17.3	NM87	RC 1 ¼	19.1	RC87
40	M(70)	91	8.5	23.3	30.5	234.7	130	68.0	M70 × 2	55	55	G 1 ½	22	GM88	NPT 1 ½	17.3	NM88	RC 1 ½	19.1	RC88
	N(90)	120				294.4	130	68.3	M70 × 2	55	55	G 1 ½	22	GM88	NPT 1 ½	17.3	NM88	RC 1 ½	19.1	RC88
	P(130)	159				346.7	130	68.0	M70 × 2	55	55	G 1 ½	22	GM88	NPT 1 ½	17.3	NM88	RC 1 ½	19.1	RC88
50	M(70)	91	8.5	23.3	30.5	245.5	150	72.0	M84 × 2	70	70	G 2	24	GM89	NPT 2	17.6	NM89	RC 2	23.4	RC89
	N(90)	120				310.7	150	72.0	M84 × 2	70	70	G 2	24	GM89	NPT 2	17.6	NM89	RC 2	23.4	RC89
	P(130)	159				353.7	150	72.0	M84 × 2	70	70	G 2	24	GM89	NPT 2	17.6	NM89	RC 2	23.4	RC89

Ordering chart Type 2106, flow direction below the seat (for gases and liquids)

G thread acc. to EN ISO 228-1

Control function	Port connection	Orifice [mm]	Actuator size Ø [mm]	K _v value water [m³/h]		Min. pilot pressure [bar]	Max. operating pressure to 180 °C [bar]		Weight [kg]	Article no. PA actuator
				1 → 2	2 → 3		1 → 2	2 → 3 2 → 1		
A 3/2 way, normally closed (NC) (port 1)	G ½	15	50	7	4.5	5.5	16	16	1.5	282698 页
			70	7	4.5	4.5	16	16	2.2	282701 页
	G ¾	20	50	9	6.2	5.5	16	16	1.4	282702 页
			70	9	6.2	4.5	16	16	2.1	282704 页
	G 1	25	50	17	11	5.5	9	11	1.9	282705 页
			70	17	11	4.5	16	16	2.6	282706 页
	G 1 ¼	32	70	32	21	4.5	8	11	3.9	282707 页
			90	32	21	5.1	11	16	5.4	282709 页
	G 1 ½	40	70	35	24	4.5	7	11	3.7	282711 页
			90	35	24	5.1	12	16	5.2	282712 页
	G 2	50	90	51	35	5.1	9	8	7.3	282715 页
			130	51	35	4.9	16	16	10.4	282716 页

NPT thread acc. to ANSI B 1.20.1

Control function	Port connection	Orifice [mm]	Actuator size Ø [mm]	K _v value water [m³/h]		Min. pilot pressure [bar]	Max. operating pressure to 180 °C [bar]		Weight [kg]	Article no. PA actuator
				1 → 2	2 → 3		1 → 2	2 → 3 2 → 1		
A 3/2 way, normally closed (NC) (port 1)	NPT ½	15	50	7	4.5	5.5	16	16	1.5	292478 页
			70	7	4.5	4.5	16	16	2.2	292531 页
	NPT ¾	20	50	9	6.2	5.5	16	16	1.4	292532 页
			70	9	6.2	4.5	16	16	2.1	292533 页
	NPT 1	25	50	17	11	5.5	9	11	1.9	292534 页
			70	17	11	4.5	16	16	2.6	292535 页
	NPT 1 ¼	32	70	32	21	4.5	8	11	3.9	292536 页
			90	32	21	5.1	11	16	5.4	292537 页
	NPT 1 ½	40	70	35	24	4.5	7	11	3.7	292538 页
			90	35	24	5.1	12	16	5.2	292539 页
	NPT 2	50	90	51	35	5.1	9	8	7.3	292540 页
			130	51	35	4.9	16	16	10.4	292541 页

i Further versions on request

 Port connection
NPT thread, RC thread

Note
 You can fill out the fields directly in the PDF file before printing out the form.

Valve system On/Off ELEMENT Type 8801-GE – request for quotation

▶ Please fill out and send to your nearest Bürkert facility* with your inquiry or order

Company	Contact person
Customer no.	Department
Address	Tel./Fax
Postcode/town	E-Mail

= mandatory fields to fill out Quantity Required delivery date

Operating data

Pipe line DN PN

Process medium

Type of media Liquid Steam Gas

Valve features

Seal material PTFE Other

Nominal pressure PN

Orifice DN

Thread version ISO 228 NPT RC

Pilot pressure min. max.









Atex II 2GD Mechanical

Please specify item no. (if known):

Valve system On/Off ELEMENT Type 8801-GE – request for quotation, *continued*

Automation unit features

Click on the orange box "More info"... you will come to our website for the resp. product where you can download the data sheet.

Control Head		Pneumatic Control Unit / Feedback	
<input type="checkbox"/> Type 8691  For actuator size Ø 70/90/130 mm 	<input type="checkbox"/> Type 8695  For actuator size Ø 50 mm 	<input type="checkbox"/> Type 8690  For actuator size Ø 70/90/130 mm 	<input type="checkbox"/> Type 8697  For actuator size Ø 50 mm 
<ul style="list-style-type: none"> Inductive position sensor with automatic Teach function Coloured high power LEDs With/without pilot valve for single or double-acting actuators Fieldbus communication Hygienic stainless steel design 		<ul style="list-style-type: none"> visual status indicator Micro- or proximity switches for end position feedback With/ without pilot valve for single or double-acting actuators Optional intrinsically safe version acc. to ATEX / IECEx 	
Pneumatic function <input type="checkbox"/> Single-acting <input type="checkbox"/> Double-acting <input type="checkbox"/> Without pilot valve	Electrical connection <input type="checkbox"/> Cable gland <input type="checkbox"/> M12 connector	Pneumatic function <input type="checkbox"/> Single-acting <input type="checkbox"/> Double-acting (only with 8690) <input type="checkbox"/> Without pilot valve	Number of Position feedback switches <input type="checkbox"/> 1x <input type="checkbox"/> 2x
Communication <input type="checkbox"/> AS-Interface <input type="checkbox"/> DeviceNet <input type="checkbox"/> without	Approvals <input type="checkbox"/> ATEX cat. 3GD, IECEx <input type="checkbox"/> without	Position feedback switches <input type="checkbox"/> Micro-switch 24 V DC <input type="checkbox"/> Micro-switch 50 – 225 V DC/AC (only 8697) <input type="checkbox"/> Inductive switch 3-wire PNP <input type="checkbox"/> Inductive switch 2-wire NAMUR <input type="checkbox"/> Inductive switch 2-wire 24 V DC <input type="checkbox"/> without	Electrical connection <input type="checkbox"/> Cable gland <input type="checkbox"/> M12 connector
		Approvals <input type="checkbox"/> ATEX cat. 3GD, IECEx <input type="checkbox"/> ATEX cat. 2DG, IECEx <input type="checkbox"/> without	

Comment / sketch

* To find your nearest Bürkert office, click on the orange box →

www.burkert.com

In case of special application conditions,
please consult for advice.

Subject to alteration.
© Christian Bürkert GmbH & Co. KG

1802/6_EU-en_00895289